



Air Pressure Sensing Switch with Adjustable Set Point Range

APPLICATION

Model AFS-298-112 is a general purpose proving switch designed for HVAC and Energy Management applications. It may be used to sense positive, negative, or differential air pressure.

GENERAL DESCRIPTION & OPERATION

The plated housing contains a diaphragm, a calibration spring, and a snap-acting SPDT switch. The barbed sample line connections located on each side of the diaphragm accept flexible tubing. The electrical connection consists of male 1/4-inch quick connect terminals.

MOUNTING (SEE FIGURE 1)

Select a mounting location which is free from vibration. The AFS-298-112 must be mounted with the diaphragm in any vertical plane in order to maintain the specified operating set point. Avoid mounting with the sample line connections in the "up" position.

Surface mount via the two 3/16" diameter holes on the zinc-plated strap bracket. The mounting holes are 3-7/8" apart.

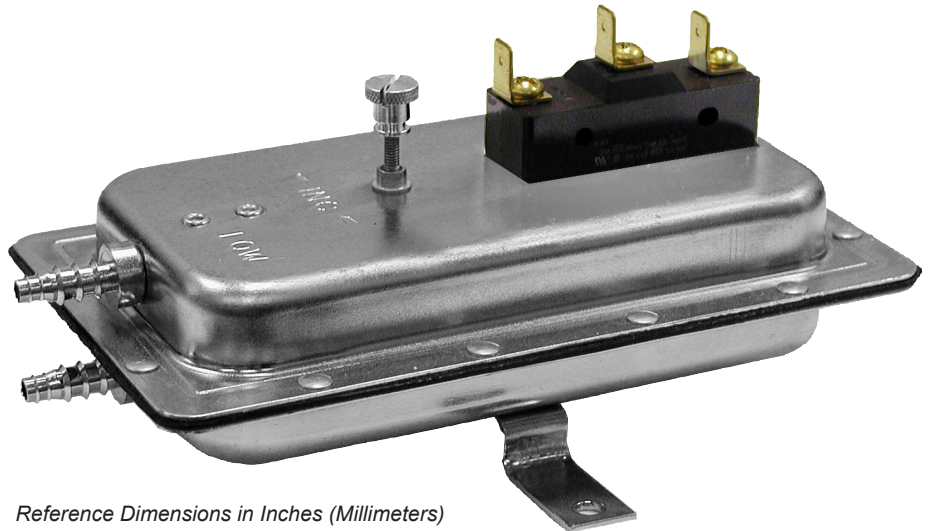

Reference Dimensions in Inches (Millimeters)

AIR SAMPLING CONNECTION (FIGURE 2)

The AFS-298-112 is equipped with two barbed, slip-on sample line connections, situated on either side of the diaphragm as shown in Figure 2. These connections are suitable for flexible tubing. Locate the sampling probe a minimum of 1.5 duct diameters downstream from the air source. For sample lines up to 10 feet in length, 1/4"OD tubing is acceptable. For lines up to 20 feet, use 1/4"ID tubing. For lines up to 60 feet, use 1/2" ID tubing. Install the sampling probe as close to the center of the airstream as possible.

Refer to Figure 2 to identify the **high pressure inlet (H)** and the **low pressure inlet (L)**. Select one of the five application options listed below, and connect the sample lines as recommended.

Positive pressure only: Connect the sample line to inlet H; inlet L remains open to the atmosphere.

Figure 2

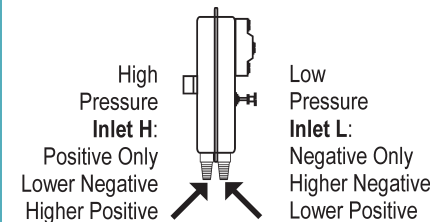

Figure 3

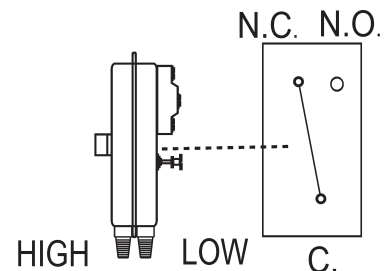
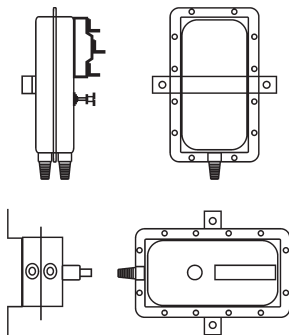

Figure 1



Mount with the diaphragm in any vertical plane to obtain the lowest specified operating set point.



Figure 4

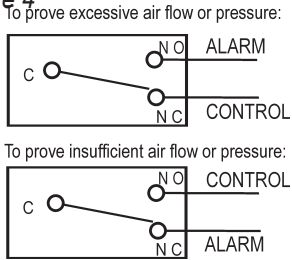

Negative pressure only: Connect the sample line to inlet L; inlet H remains open to the atmosphere.

Two Negative Samples: Connect the higher negative sample to inlet L. Connect the lower negative sample to inlet H.

Two Positive Samples: Connect the higher positive sample to inlet H. Connect the lower positive sample to inlet L.

One Positive and One Negative Sample: Connect the positive sample to inlet H. Connect the negative sample to inlet L.

ELECTRICAL CONNECTIONS (FIGURES 3 & 4)

Before pressure is applied to the diaphragm, the switch contacts will be in the normally closed (NC) position. The snap switch has 90° male quick connect terminals. Wire control and alarm functions as shown in Figure 4.

FIELD ADJUSTMENT

The adjustment range of an **AFS-298-112** Air Switch is 0.05±0.02" w.c. to 12.0" w.c.

To adjust the set point, turn the adjusting screw counterclockwise until motion has stopped. Next, turn the adjusting screw 4 complete turns clockwise to engage the spring.

From this point, the next ten turns will be used for the actual calibration. **Each full turn represents approximately 1.2" w.c.**

Please note: To properly calibrate an air switch, a digital manometer or other measuring device should be used to confirm the actual set point.

PRESSURE CONVERSION TABLE

1" H ₂ O	=	0.0361 lbs/sq. in.	=	0.0735 in. Hg
1 in Hg	=	0.491 lbs/sq. in.	=	13.6 in H ₂ O
1 psi	=	27.7 in. H ₂ O	=	2.036 in. Hg

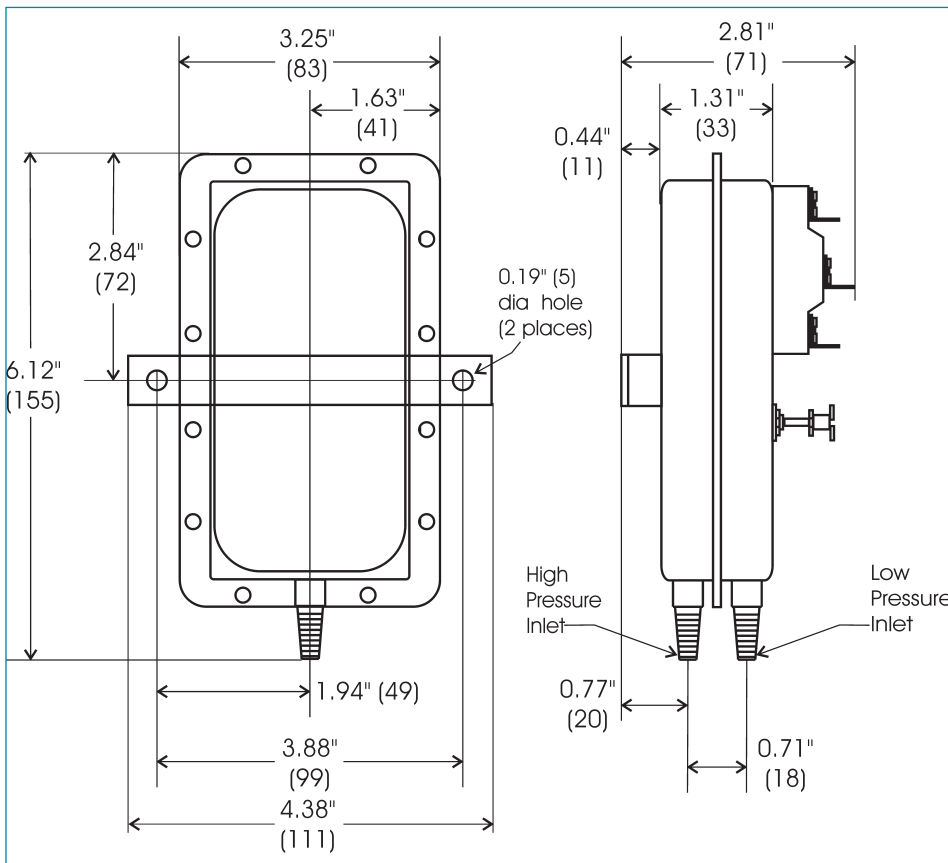

SPECIFICATIONS

MODEL AFS-298-112 AIR PRESSURE SENSING SWITCH WITH ADJUSTABLE SET POINT RANGE

Mounting Position:

Mount with the diaphragm in any vertical plane.

Set Point Range: 0.05 ±0.02" w.c. to 12.0" w.c.

Field Adjustable "Operate Range": 0.07" w.c. to 12.0" w.c.

Field Adjustable "Release Range": 0.04" w.c. to 11.2" w.c.

Approximate Switch Differential: Progressive, increasing from 0.02±0.01" w.c. at minimum set point to approximately 0.8" w.c. at maximum set point.

Measured Media: Air or combustion by-products that will not degrade silicone.

Maximum Pressure: ½ psi (0.03 bar)

Operating Temperature Range: -40 to 180F (-40.0 to 82.2C)

Life: 100,000 cycles minimum at ½ psi maximum pressure each cycle and at maximum rated electrical load.

Electrical Rating: 300 VA pilot duty at 115 to 277 VAC; 15 amp noninductive to 277 VAC, 60 Hz.

Contact Arrangement: SPDT

Electrical Connections: Male, ¼", 90° quick-connect terminals

Sample Line Connectors: Two barbed ¼" slip-on connectors, suitable for flexible tubing

Approvals: UL, CSA

Shipping Weight: 1.2 l

Accessories:

- Sample line probes
- Orifice plugs (pulsation dampers)